

Summit SB38

Quick Start Guide

SUMMIT

HOW TO USE THIS GUIDE

We want you to be enjoying your first meal on your new Weber Summit as soon as possible! We've created this quick guide to provide you with the preheat and cook settings required for a range of different cooking styles. For recipe inspiration, you can visit our [website](#).

All our recipes for the Weber Summit reference the cooking method (direct or indirect) and the heat range – this corresponds to the settings you'll find in the tables on the following pages. It also references the accessories you'll need to set up your barbecue for certain cooking methods. Helpful videos are also available on the [website](#).

Be sure to read the information below and understand the legend for the icons, and you'll be making flavourful memories in no time!

Temperature ranges: The temperature ranges are provided as a guide only. You should easily achieve a temperature within the range by using the settings indicated.

Preheating: Whether you're using the direct or indirect method, it's important to preheat your barbecue with the lid down before use. Specific preheat times will vary depending on what you're cooking. Refer to the tables for preheat times and settings.

Lid down cooking: For the past 70 years, Weber barbecues have been specifically designed to be used with the lid down. This helps to create and impart that famous Weber flavour, and you'll find that your food cooks quicker too!

Helpful tips to get you started:

- **Top-Down, High-Heat Infrared Burner:** The IR burner directs blazing high heat onto the top of your food, making it ideal for browning, caramelising, or creating a crust. The adjustable upper cooking grill allows you to set it in three positions. The highest position will give you the most intense browning. Once you have finished cooking, turn your main burners off, place your food on the appropriate level grill, and light the IR burner on either High or Low.
NOTE: Always keep the lid OPEN while using the IR burner on the high heat setting.
- **Cleaning and maintenance:** It is best to clean your barbecue before each use. Once preheated, use a stainless-steel grill brush to brush the grills clean. We recommend thorough cleaning of your Weber Summit every 5 cooks or so. Refer to your Owner's Manual for detailed instructions.
- **Crafted accessories:** Your Weber Summit comes with a Weber Crafted Outdoor Kitchen Collection frame. This accessory allows you to use a hotplate (included), grilling basket, pizza stone, or sear grate (available for purchase separately).

Factors that may impact preheat times, cook settings or times: This guide provides suggested settings for various cooking methods and outcomes. These have been tested in an outdoor, sheltered environment in an ambient temperature of around 20°C. As you get to know your barbecue, you may need to adjust your preheat or cooking time, or your barbecue settings, to deliver the best results for the conditions you're cooking in – or just to suit your personal taste!

Looking for recipe inspiration, tips, tricks, or advice on how to use and maintain your Weber barbecue or accessory? Find us online at www.weber.com or follow us on your favourite social media platforms today!



@weberBBQAusNz



The Weber Summit has multiple barbecuing functions, allowing you to cook in various styles.

Each cooking style requires specific barbecue and burner settings, which might seem complex at first, but we've made it simple. On the following pages, you'll find setup tables that feature icons to guide you. We recommend familiarising yourself with these icons before you start cooking.

Your Weber Summit features 5 main burners, which we've numbered from left to right (as shown in the adjacent image). Each cooking style requires setting each burner to specific positions for preheating, and then adjusting them to different settings for cooking. Simply follow the table instructions, and you'll be cooking amazing meals in no time!

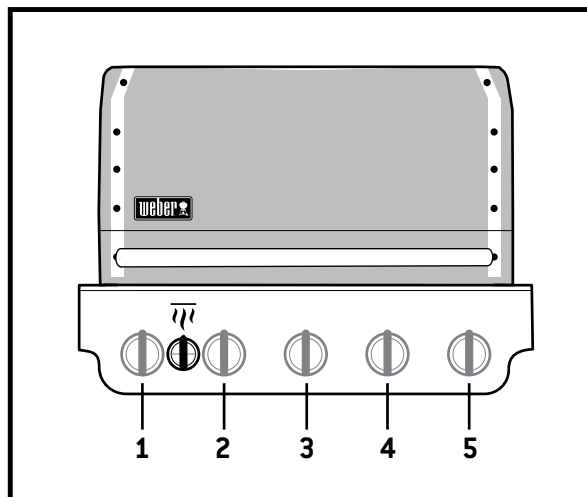

ICON LEGEND

Burner (START - HIGH)	Burner (MEDIUM)	Burner (ONE NOTCH LESS THAN MEDIUM)	Burner (LOW)	Burner (OFF)	IR Burner (HIGH)	IR Burner (LOW)

Pre-heat duration	CRAFTED Frame	CRAFTED Hotplate	CRAFTED Grilling basket	CRAFTED Sear grate	CRAFTED Pizza stone	Smoker box

Unsoaked wood chips (4 cups)	Rotisserie	Rotisserie crisping basket	Large drip pan	Small drip pan (with 500 mL water)

Looking for recipe inspiration, tips, tricks, or advice on how to use and maintain your Weber barbecue or accessory? Find us online at www.weber.com or follow us on your favourite social media platforms today!



@weberBBQAusNz



Direct Cooking

The direct method is used for grilling or searing food directly above a heat source and directly on the cooking grill, sear grate, or grilling basket.

A slight variation on the standard direct cooking method involves the use of a solid hotplate. This accessory is ideal for foods that may fall through the cooking grill, such as eggs, onion rings, or even pancakes.

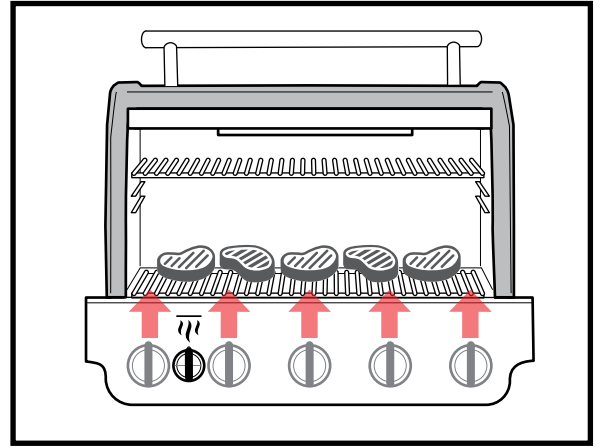

	COOKING METHOD AND TEMPERATURE RANGE	PREHEAT		ACCESSORIES REQUIRED	COOK SETTING
GRILL	Direct High Heat (250°C - 290°C)	All burners			All burners
	Direct Medium - High Heat (210°C - 250°C)	All burners			All burners
	Direct Medium Heat (180°C - 230°C)	All burners			All burners 1 notch less
SEAR GRATE	SEAR GRATE Direct High Heat (250°C - 290°C)	All burners		 Set up - Right hand side	All burners
GRILLING BASKET	GRILLING BASKET Direct Medium - High Heat (210°C - 250°C)	1+2	3+4+5 	 Set up - Right hand side	1+2 3+4+5
HOTPLATE*	HOTPLATE Direct Medium - High Heat (210°C - 250°C)	1+2	3+4+5 	 Set up - Right hand side	1+2 3+4+5
	HOTPLATE Direct Medium Heat (180°C - 230°C)	1+2	3+4+5 	 Set up - Right hand side	1+2 3+4+5

*The lid thermometer will not read accurately when using the hotplate accessory

Indirect Cooking

The indirect cooking method is used for roasting, baking, and low and slow cooking. Food is not cooked directly over a heat source or directly on the cooking grill. In the case of your Weber Summit, it's as simple as turning one or more burners off and placing your food over those unlit burners. Convection heat then circulates around your food, cooking it evenly throughout the cooking process, with no need to turn the food.

A slight variation on the standard indirect cooking method involves the use of a glazed pizza stone or rotisserie.

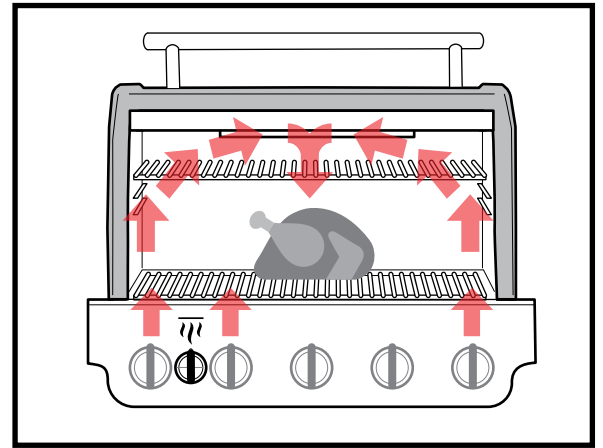

	COOKING METHOD AND TEMPERATURE RANGE	PREHEAT	ACCESSORIES REQUIRED	COOK SETTING
ROAST	ROAST Indirect High Heat (220°C - 260°C)	15 MIN		1+2+5 3+4
	ROAST Indirect Medium Heat (190°C - 230°C)	15 MIN		1+5 2 3+4
BAKE	BAKE Indirect Medium-Low Heat (170°C - 190°C)	15 MIN		1+5 2 3+4
LOW AND SLOW	LOW AND SLOW Indirect Very Low Heat (95°C - 130°C)	15 MIN	Small drip pan + 500 mL water Over 2nd burner	1+5 2+3+4
PIZZA	PIZZA Indirect High Heat (220°C - 260°C)	10 MIN	Set up - Centre of grill	1+5 2+3+4
ROTISSERIE	ROTISSERIE Indirect Medium Heat (190°C - 230°C)	15 MIN	Remove cooking grills	1+5 2+3+4
SMOKE	SMOKE Indirect Medium Heat (190°C - 230°C)	20 MIN	Over 2nd burner	1+5 2 3+4

Looking for recipe inspiration, tips, tricks, or advice on how to use and maintain your Weber barbecue or accessory? Find us online at www.weber.com or follow us on your favourite social media platforms today!



@weberBBQAusNz

