

# SUMMIT



FS38 E

## ULPG Owner's Manual



### REGISTER TODAY - SCAN THE QR CODE

Thank you for purchasing a Weber barbecue. Register your barbecue with us to be part of the Weber family. It'll allow us access the details of your barbecue if you need assistance in the future, such as a warranty claim, replacement parts or cooking advice! You can also sign up to receive product news, special offers and barbecuing tips & recipes, and more.



**Important:** Read these instructions for use carefully. Familiarise yourself with the appliance before connecting it to its gas cylinder. Keep these instructions for future reference.



#### DIGITAL OWNER'S MANUAL

To access the digital owner's manual, scan the QR Code and enter

your serial number, or browse online at [weber.com/literature-online](http://weber.com/literature-online)

Serial Number

Write your barbecue's serial number in the box above for future reference. The serial number is on the barbecue's data label.

8651304\_061724 AUNZ

## Important Safety Information

**DANGER, WARNING, and CAUTION** statements are used throughout this Owner's Manual to emphasise critical and important information. Read and follow these statements to help ensure safety and prevent property damage. The statements are defined below.

- ⚠ **DANGER:** Indicates a hazardous situation which, if not avoided, *will result in death or serious injury.*
- ⚠ **WARNING:** Indicates a hazardous situation which, if not avoided, *could result in death or serious injury.*
- ⚠ **CAUTION:** Indicates a hazardous situation which, if not avoided, *could result in minor or moderate injury.*

**USE OUTDOORS ONLY.**

**READ THE INSTRUCTIONS BEFORE USING THE APPLIANCE.**

**NOTICE TO INSTALLER:** These instructions must be left with the consumer.

**NOTICE TO CONSUMER:** Retain these instructions for future reference.

⚠ **DANGER**

**If you smell gas:**

- Shut off gas to the appliance.
- Extinguish any open flame.
- Open lid.
- If odour continues, keep away from the appliance and immediately call your gas supplier or the emergency fire services.

⚠ **WARNING**

- Do not store or use petrol or other flammable liquids or vapours in the vicinity of this or any other appliance.
- A cylinder not connected for use shall not be stored in the vicinity of this or any other appliance.

### Installation and Assembly

- ⚠ **DANGER:** This barbecue is not intended to be installed in or on recreational vehicles or boats.
- ⚠ **WARNING:** Do not use this barbecue unless all parts are in place and the barbecue was properly assembled according to the assembly instructions.
- ⚠ **WARNING:** Do not build this model of barbecue in any built-in or slide-in construction.
- ⚠ **WARNING:** Do not modify this appliance. LP gas is not natural gas. The conversion or attempted use of natural gas in a LP gas unit or LP gas in a natural gas unit is unsafe and will void your warranty.
- ⚠ **WARNING:** Do not use an adaptor at the cylinder connection.
- The installation of the barbecue must conform with the requirements of AS/NZS 5601 and the local authority – gas or electricity, etc.
- Do not install in, or connect to the consumer piping or gas supply of a boat or caravan.
- Any parts sealed by the manufacturer must not be altered by the user.

### Operation

- ⚠ **DANGER:** Only use the barbecue outdoors in a well-ventilated area. Do not use in a garage, building, breezeway, tent, any other enclosed area, or beneath overhead combustible construction.
- ⚠ **DANGER:** Do not use the barbecue in any vehicle or in any storage or cargo area of any vehicle. This includes, but is not limited to, cars, trucks, station wagons, mini-vans, sport utility vehicles, recreational vehicles, and boats.
- ⚠ **DANGER:** Do not use the barbecue within 61 cm (24 inches) of combustible materials. This includes the bottom, back and sides of the barbecue.
- ⚠ **DANGER:** Do not use the barbecue within 120 cm (48 inches) of overhead combustible materials.
- ⚠ **DANGER:** Keep the cooking area clear of flammable vapours and liquids such as petrol, alcohol, etc., and combustible materials.
- ⚠ **DANGER:** This appliance must be kept away from flammable materials during use. Do not use or store flammable materials in or near this appliance. Do not spray aerosols in the vicinity of this appliance while it is in operation.
- ⚠ **DANGER:** Do not put a barbecue cover or anything flammable on, or in the storage area under the barbecue while it is in operation or is hot.
- ⚠ **DANGER:** Should a grease fire occur, turn off all burners and leave lid closed until fire is out.
- ⚠ **WARNING:** Accessible parts may be very hot. Keep young children away.
- ⚠ **WARNING:** The use of alcohol, prescription drugs, non-prescription drugs, or illegal drugs may impair the consumer's ability to properly and safely assemble, move, store, or operate the barbecue.
- ⚠ **WARNING:** Never leave the barbecue unattended during pre-heating or use. Exercise caution when using this barbecue. The entire cookbox gets hot when in use.
- ⚠ **WARNING:** Do not move the appliance during use.
- ⚠ **WARNING:** Keep any electrical supply cord and the fuel supply hose away from any heated surfaces.
- ⚠ **WARNING:** Do not place articles on or against this appliance.
- ⚠ **CAUTION:** This product has been safety-tested and is only certified for use in a specific country. Refer to country designation located on outside of box.
- Do not use charcoal, briquettes or lava rock in the barbecue.



**FOR THE FULL WEBER BARBECUE EXPERIENCE**

<p><b>REGISTER YOUR PRODUCT</b></p> <p>Scan the QR Code</p>  <p>OR register at <a href="http://weber-anz.registria.com">weber-anz.registria.com</a></p>	<p><b>VIEW YOUR USER AND RECIPE GUIDE</b></p>  <p>Scan the QR Code</p>
--------------------------------------------------------------------------------------------------------------------------------------------------------------------------------------------------------------------------------------------	-----------------------------------------------------------------------------------------------------------------------------------------------------------

© 2024 Weber-Stephen Products LLC. Weber, the  silhouette, and the kettle configuration are registered U.S. trademarks of Weber-Stephen Products LLC. The shape of the Weber Q is a trademark of Weber-Stephen Products LLC



## Storage and/or Nonuse

- ⚠ **WARNING:** Turn off the gas supply at the cylinder after use.
- ⚠ **WARNING:** Cylinders must be stored outdoors out of the reach of children and must not be stored in a building, garage or any other enclosed space.
- ⚠ **WARNING:** After a period of storage and/or nonuse, the barbecue should be checked for gas leaks and burner obstructions before use.
- Storage of the barbecue indoors is permissible only if the cylinder is disconnected and removed from the barbecue.

## Electrical Supply

- ⚠ **WARNING:** This appliance is not intended for use by persons (including children) with reduced physical, sensory or mental capabilities, or lack of experience and knowledge, unless they have been given supervision or instruction concerning use of the appliance by a person responsible for their safety.
- ⚠ **WARNING:** Children should be supervised to ensure that they do not play with the appliance.
- ⚠ **WARNING:** Only use the power supply unit provided with this appliance.
- ⚠ **WARNING:** This appliance incorporates an earth connection for functional purposes only.
- ⚠ **WARNING:** To protect against risk of electric shock, do not immerse lead or plugs in water or other liquid.
- ⚠ **WARNING:** Unplug from the outlet when not in use and before cleaning. Allow to cool before putting on or taking off parts.
- ⚠ **WARNING:** Do not operate any outdoor cooking gas appliance with a damaged lead or plug, or after the appliance malfunctions or has been damaged in any manner. Contact the Customer Service Representative in your area using the contact information on our web site. Log onto [www.weber.com](http://www.weber.com)
- ⚠ **WARNING:** Do not let the lead hang over the edge of a table or touch hot surfaces.
- ⚠ **WARNING:** Do not use an outdoor cooking gas appliance for purposes other than intended.
- ⚠ **WARNING:** On connecting, first connect the plug to the outdoor cooking gas appliance and then plug the appliance into the outlet.
- ⚠ **WARNING:** Only use a residual current device (RCD) protected circuit with this outdoor cooking gas appliance.
- ⚠ **WARNING:** Never remove the earthing plug or use with a two-prong adapter.
- ⚠ **WARNING:** Only use extension leads with a tripolar earthing plug, rated for the equipment's power, and approved for outdoor use.
- Do not connect two or more extension leads together.
- Always ensure that the electrical socket being used has the correct voltage (230 V).

- ⚠ **DANGER:** Do not line the slide-out grease tray or cookbox with aluminium foil.
- ⚠ **DANGER:** Check the slide-out grease tray and catch pan for grease build-up before each use. Remove excess grease to avoid a grease fire.
- ⚠ **WARNING:** Use caution when removing catch pan and disposing of hot grease.
- ⚠ **WARNING:** Use heat-resistant barbecue mitts or gloves (conforming to EN 407, Contact Heat rating level 2 or greater) when operating barbecue.
- ⚠ **WARNING:** Barbecue brushes should be checked for loose bristles and excessive wear on a regular basis. Replace the brush if any loose bristles are found on cooking grills or brush. WEBER recommends purchasing a new stainless steel bristle barbecue brush at the beginning of every spring.
- ⚠ **WARNING:** If the hose is found to be damaged in any way, do not use the barbecue. Replace using only WEBER authorised replacement hose.
- ⚠ **WARNING:** Keep ventilation openings around tank clear and free of debris.
- ⚠ **WARNING:** Keep any electrical supply cord and the fuel supply hose away from heated surfaces.

## Limited Warranty

Thank you for purchasing a WEBER product. Weber-Stephen Products LLC, 1415 S. Roselle Road, Palatine, Illinois 60067 ("WEBER") prides itself on delivering a safe, durable, and reliable product.

This is WEBER'S Limited Warranty ("Warranty") provided to you at no extra charge. It contains the information you will need to have your WEBER product repaired in the unlikely event of a failure or defect.

Pursuant to the Australia Consumer Law, the Owner has several rights in case the product is defective. Those rights include that the product is fit for purpose, acceptable in appearance and finish, free from defects and is safe and durable. These and other statutory rights remain unaffected by this warranty provision. In fact, this warranty grants additional rights to the Owner that are independent from statutory warranty provisions.

### WEBER'S LIMITED WARRANTY

WEBER warrants, to the purchaser of the WEBER product (or in the case of a gift or promotional situation, the person for whom it was purchased as a gift or promotional item) ("Owner"), that the WEBER product is free from defects in material and workmanship for the period(s) of time specified below when assembled and operated in accordance with the accompanying Owner's Manual, normal wear and tear excluded. (Note: If you lose or misplace your WEBER Owner's Manual, a replacement is available online at [www.weber.com](http://www.weber.com).) WEBER agrees within the framework of this warranty to repair or replace the part that is defective in material or workmanship subject to the limitations, and exclusions listed below. TO THE EXTENT ALLOWABLE BY APPLICABLE LAW, THIS WARRANTY IS EXTENDED ONLY TO THE ORIGINAL PURCHASER AND IS NOT TRANSFERABLE TO SUBSEQUENT OWNERS, EXCEPT IN THE CASE OF GIFTS AND PROMOTIONAL ITEMS AS NOTED ABOVE.

WEBER stands by its products and is happy to provide you with the Warranty described for material defects in the barbecue or its relevant components, normal wear and tear excepted.

- 'Normal wear and tear' includes cosmetic and other immaterial deterioration that may come with ownership of your barbecue over time, such as surface rust, dents / scratches, etc.

However, WEBER will honor this Warranty for the barbecue or its relevant components where damage or dysfunction results from a material defect.

- 'Material defect' includes rust through or burn through of certain parts, or other damage or failure inhibiting your ability to safely / properly use your barbecue.

### OWNER'S RESPONSIBILITIES UNDER THIS WARRANTY

To ensure trouble-free warranty coverage, it is important (but it is not required) that you register your WEBER product online at [www.weber.com](http://www.weber.com). Please also retain your original sales receipt and/or invoice. Registering your WEBER product confirms your warranty coverage and provides a direct link between you and WEBER in case we need to contact you. If you have not had time to register your barbecue before calling for Warranty service, please have the following information available when you do call: Name – Address – Phone Number – Email – Serial Number – Purchase Date – Purchase Dealer – Model – Color – Primary Issue

The above warranty only applies if the Owner takes reasonable care of the WEBER product by following all assembly instructions, usage instructions, and preventative maintenance as outlined in the accompanying Owner's Manual, unless the Owner can prove that the defect or failure is independent of non-compliance with the above mentioned obligations. If you live in a coastal area, or have your product located near a pool, maintenance includes regular washing and rinsing of the exterior surfaces as outlined in the accompanying Owner's Manual.

Our goods come with guarantees that cannot be excluded under the Australian Consumer Law. You are entitled to a replacement or refund for a major failure and for compensation for any other reasonably foreseeable loss or damage. You are also entitled to have the goods repaired or replaced if the goods fail to be of acceptable quality and the failure does not amount to a major failure.

The benefits given under this Limited Warranty are in addition to other rights and remedies you have under the Australian Consumer Law in relation to this WEBER gas barbecue.

### WARRANTY HANDLING / EXCLUSION OF WARRANTY

If you believe that you have a part which is covered by this Warranty, please contact WEBER Customer Service using the contact information on our website ([www.weber.com](http://www.weber.com), or such country-specific website to which Owner may be redirected). WEBER will, upon investigation, repair or replace (at its option) a defective part that is covered by this Warranty. In the event that repair or replacement are not possible, WEBER may choose (at its option) to replace the barbecue in question with a new barbecue of equal or greater value. WEBER may ask you to return parts for inspection, shipping charges to be pre-paid by owner.

When you contact Customer Service, please have the following information available:  
Name – Address – Phone Number – Email – Serial Number – Purchase Date – Purchase Dealer – Model – Color – Primary Issue

This WARRANTY lapses if there are damages, deteriorations, discolorations, and/or rust for which WEBER is not responsible caused by:

- Abuse, misuse, alteration, modification, misapplication, vandalism, neglect, improper assembly or installation, and failure to properly perform normal and routine maintenance;
- Insects (such as spiders) and rodents (such as squirrels), including but not limited to damage to burner tubes and/or gas hoses;
- Exposure to salt air and/or chlorine sources such as swimming pools and hot tubs/spas;
- Severe weather conditions such as hail, hurricanes, earthquakes, tsunamis or surges, tornadoes or severe storms.
- Acid rain and other environmental factors.

Using third party parts will not void this Warranty. However, any parts that are used and/or installed on your WEBER product that are not genuine WEBER parts are not covered by this Warranty. In addition, any damages that result from the use and/or installation of parts on your WEBER product that are not genuine WEBER parts are not covered by this Warranty. Any conversion of a gas barbecue not authorised by WEBER and performed by a WEBER authorised service technician will void this Warranty.

### PRODUCT WARRANTY PERIODS

Cookbox:

15 years, no rust through/burn through  
(2 years paint excluding fading or discoloration)

Lid assembly:

15 years, no rust through/burn through  
(2 years paint excluding fading or discoloration)

Burners:

10 years, no rust through/burn through

Stainless steel cooking grills:

10 years, no rust through/burn through

Stainless steel FLAVORIZER BARS:

10 years, no rust through/burn through

Electronics and WEBER CONNECT Components:

3 years

All remaining parts:

5 years

### DISCLAIMERS

APART FROM THE WARRANTY AND DISCLAIMERS AS DESCRIBED IN THIS WARRANTY STATEMENT, THERE ARE EXPLICITLY NO FURTHER WARRANTY OR VOLUNTARY DECLARATIONS OF LIABILITY GIVEN HERE WHICH GO BEYOND THE STATUTORY LIABILITY APPLYING TO WEBER. THE PRESENT WARRANTY STATEMENT ALSO DOES NOT LIMIT OR EXCLUDE SITUATIONS OR CLAIMS WHERE WEBER HAS MANDATORY LIABILITY AS PRESCRIBED BY STATUTE.

NO WARRANTIES SHALL APPLY AFTER THE APPLICABLE PERIODS OF THIS WARRANTY. NO OTHER WARRANTIES GIVEN BY ANY PERSON, INCLUDING A DEALER OR RETAILER, WITH RESPECT TO ANY PRODUCT (SUCH AS ANY "EXTENDED WARRANTIES"), SHALL BIND WEBER. THE EXCLUSIVE REMEDY OF THIS WARRANTY IS REPAIR OR REPLACEMENT OF THE PART OR PRODUCT.

IN NO EVENT UNDER THIS WARRANTY SHALL RECOVERY OF ANY KIND BE GREATER THAN THE AMOUNT OF THE PURCHASE PRICE OF THE WEBER PRODUCT SOLD.

YOU ASSUME THE RISK AND LIABILITY FOR LOSS, DAMAGE, OR INJURY TO YOU AND YOUR PROPERTY AND/OR TO OTHERS AND THEIR PROPERTY ARISING OUT OF THE MISUSE OR ABUSE OF THE PRODUCT OR FAILURE TO FOLLOW INSTRUCTIONS PROVIDED BY WEBER IN THE ACCOMPANYING OWNER'S MANUAL.

PARTS AND ACCESSORIES REPLACED UNDER THIS WARRANTY ARE WARRANTED ONLY FOR THE BALANCE OF THE ABOVE MENTIONED ORIGINAL WARRANTY PERIOD(S).

THIS WARRANTY APPLIES TO PRIVATE SINGLE FAMILY HOME OR APARTMENT USE ONLY AND DOES NOT APPLY TO WEBER BARBECUES USED IN COMMERCIAL, COMMUNAL OR MULTI-UNIT SETTINGS SUCH AS RESTAURANTS, HOTELS, RESORTS, OR RENTAL PROPERTIES.

WEBER MAY FROM TIME TO TIME CHANGE THE DESIGN OF ITS PRODUCTS. NOTHING CONTAINED IN THIS WARRANTY SHALL BE CONSTRUED AS OBLIGATING WEBER TO INCORPORATE SUCH DESIGN CHANGES INTO PREVIOUSLY MANUFACTURED PRODUCTS, NOR SHALL SUCH CHANGES BE CONSTRUED AS AN ADMISSION THAT PREVIOUS DESIGNS WERE DEFECTIVE.

**Weber-Stephen Products Co. (Australia) Pty Ltd.**

Level 1, 142-144 Fullarton Road  
ROSE PARK SA 5067 AUSTRALIA  
+61 8 8221 6111

**Weber-Stephen Products New Zealand**

25B O'Rorke Road  
Penrose, Auckland 1061 NEW ZEALAND  
+64 9 279 7133

### Considerations for Locating your Barbecue

Any enclosure in which the appliance is used shall comply with one of the following:

- An enclosure with walls on all sides, but at least one permanent opening at ground level and no overhead cover **(A)**.
- Within a partial enclosure that includes an overhead cover and no more than two walls **(B)**.
- Within a partial enclosure that includes an overhead cover and more than two walls, the following shall apply **(C)**:
  - (i) at least 25% of the total wall area is completely open; and
  - (ii) at least 30% of the remaining wall area is open and unrestricted.
- In the case of balconies, at least 20% of the total of the side, back and front wall areas shall be and remain open and unrestricted.

**A**

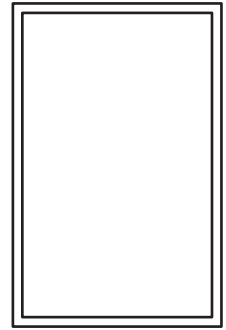
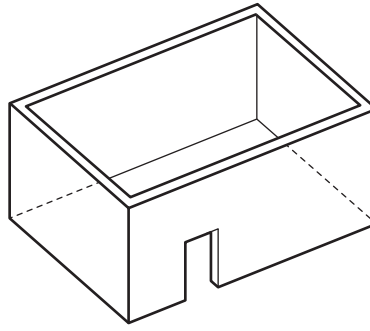

**B**

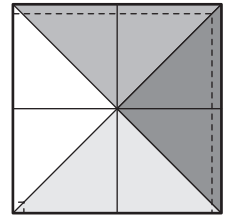
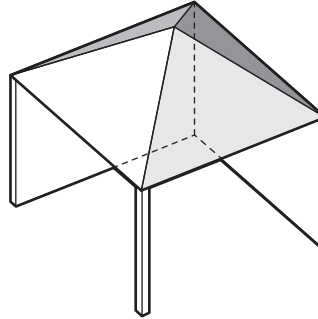

Both ends open

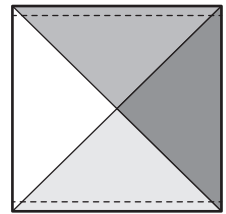
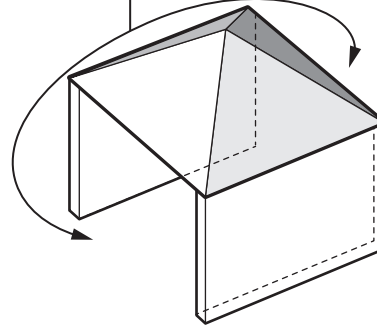

**C**

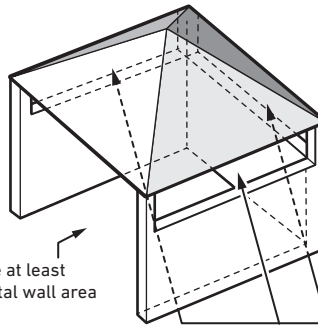

Open side at least 25% of total wall area

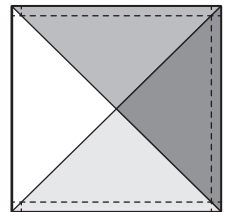

30% or more in total of the remaining wall area is open and unrestricted

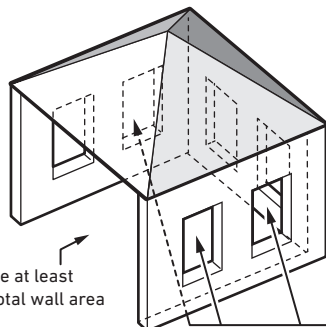

Open side at least 25% of total wall area

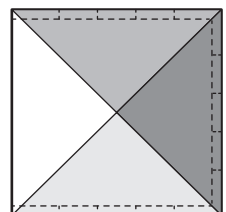

30% or more in total of the remaining wall area is open and unrestricted

**△ IMPORTANT:** This appliance shall only be used in an above ground open-air situation with natural ventilation, without stagnant areas, where gas leakage and products of combustion are rapidly dispersed by wind and natural convection.

## Important Information about ULPG & Gas Connections

### What is ULPG?

Liquefied petroleum gas, also called ULPG, is the flammable, petroleum-based product used to fuel your barbecue. It is a gas at moderate temperatures and pressure when it is not contained. But at moderate pressure inside a container, such as a cylinder, ULPG is a liquid. As pressure is released from the cylinder, the liquid readily vaporises and becomes gas.

### Safe Handling Tips for Cylinders

- A dented or rusty cylinder may be hazardous and should be checked by your supplier. Do not use a cylinder with a damaged valve.
- Although your cylinder may appear to be empty, gas may still be present, and the cylinder should be transported and stored accordingly.
- The cylinder must be installed, transported, and stored in an upright, secure position. Cylinders should not be dropped or handled roughly.
- Never store or transport the cylinder where temperatures can reach 51.7°C (125°F) (the cylinder will become too hot to hold by hand). Use caution in freezing conditions as well.
- Routinely check the cylinder to ensure the test date has not expired. Do not use a cylinder which has an expired test date.

### Cylinder Requirements

- Use cylinders with a minimum capacity of 8.5 kg.

### What is a Regulator?

Your gas barbecue is equipped with a pressure regulator, which is a device to control and maintain uniform gas pressure as gas is released from the cylinder.

### General Specifications

- Refer to data plate on barbecue for gas type, consumption, pressures and injector sizing details.
- Gas inlet connection - 3/8" SAE Flare with 5/8" UNF thread.

### Regulator and Hose Requirements

- The pressure regulator supplied with the barbecue must be used. This regulator is set for 2,8 kPa and complies with the requirements of AS/NZS 5601.
- Avoid kinking the hose.
- Replacement regulator and hose assemblies must be as specified by Weber-Stephen Products LLC.

## Cylinder Connection

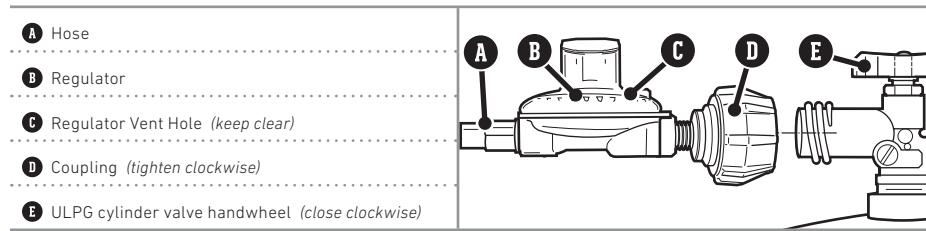

## SUMMIT Burner Valve Orifice Sizes & Consumption Data

Gas Category	BURNER VALVE ORIFICE SIZES
I <sub>3B/P</sub> (30 mbar or 2.8 kPa)	FS38 Models
	Main Burners 1.03 mm Infrared Broiler 1.19 mm Side Burner 1.02 mm
TOTAL CONSUMPTION DATA	
	FS38 Models
	100.4 MJ/h

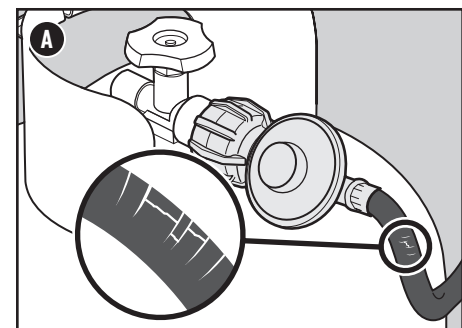

### Inspect the Hose

Routine inspection of the hose is necessary.

- 1) Confirm that the barbecue is off and cool.
- 2) Check hose for any signs of cracking, abrasions, or cuts (**A**). If the hose is found to be damaged in any way, do not use the barbecue.

**⚠ WARNING:** If the hose is found to be damaged in any way, do not use the barbecue. Replace using only WEBER authorised replacement hose.

**⚠ IMPORTANT:** We recommend that you replace the gas hose assembly on your gas barbecue every five years. Some countries may have requirements that the gas hose be replaced within less than five years, in which case that country's requirement would take precedence.

For replacement hose, regulator, and valve assemblies, contact the Customer Service Team using the contact information on our website. Visit [weber.com](http://weber.com).

## LPG Cylinder Installation

### Installation Location

The LPG cylinder is hung onto the cylinder scale which is located inside the cabinet. The LPG cylinder will hang on the cylinder scale from the collar assembly (the metal protective ring around the cylinder valve) (A).

### Inspect the LPG Cylinder

- 1) Confirm that the cylinder valve is fully closed. Close by turning valve clockwise.
- 2) Confirm that the cylinder valve is the proper mating type for the regulator (B).
- 3) Inspect the cylinder valve, including the internal rubber seal for damage or debris (C). If damaged, return LPG cylinder to local retailer.

### Install The LPG Cylinder

- 1) Check that all burner control knobs are in the off O position. Check by pushing in and turning knobs clockwise.
- 2) Lift cylinder into position on the cylinder scale (D).
- 3) Screw the regulator coupling onto the cylinder valve, turning clockwise (E). Hand-tighten only. Using a wrench could damage the regulator coupling and could cause a leak. Proceed to "CHECKING FOR GAS LEAKS."

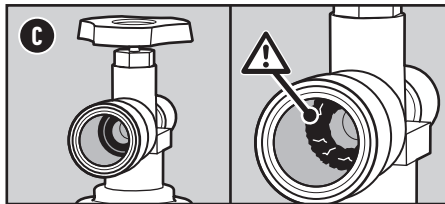
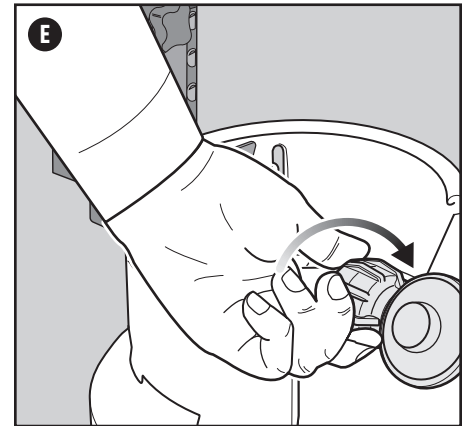
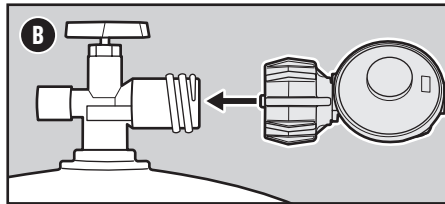
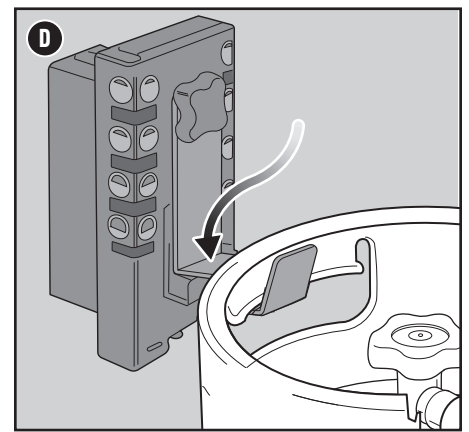
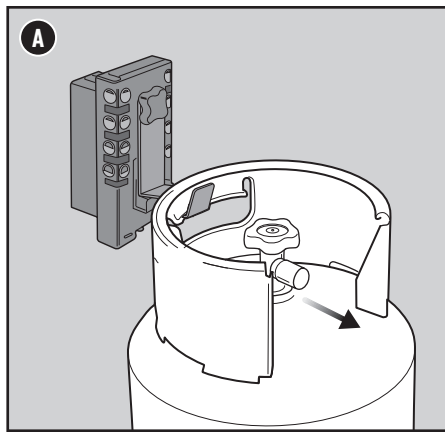

## Refilling or Replacing an LPG Cylinder

### How Much Fuel is in the LPG Cylinder?

The fuel scale indicates the amount of fuel in an LPG cylinder once the cylinder is hung from the scale. The fuel level is checked by viewing the indicator line located on the scale inside of the cabinet. Some models include an indicator on the front of the barbecue. The indicator points to a full cylinder (A), and gradually moves to indicate when the cylinder is empty (B) and needs to be removed to replace or refill.

### Removal of the LPG Cylinder

- 1) Confirm that the cylinder valve is fully closed. Close by turning valve clockwise (C).
- 2) Unscrew regulator coupling by turning anti-clockwise by hand (D).
- 3) Lift cylinder off cylinder scale.

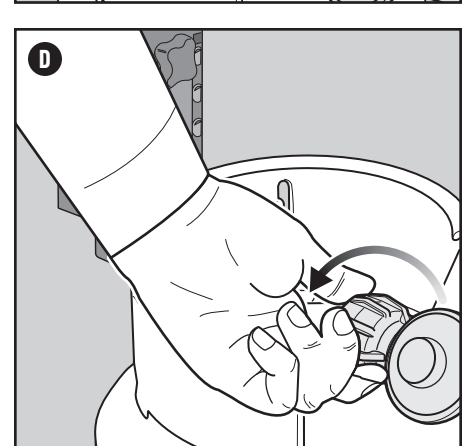
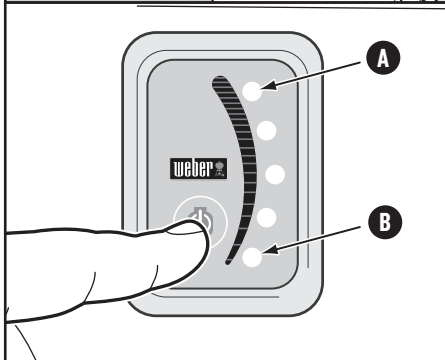
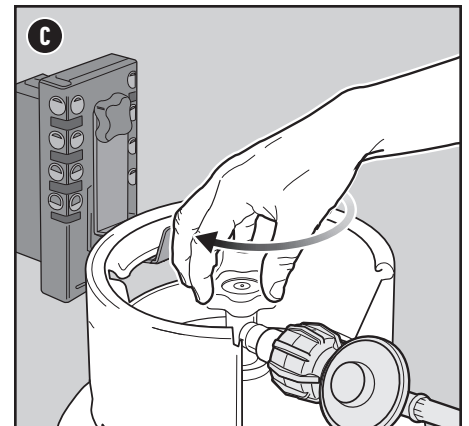
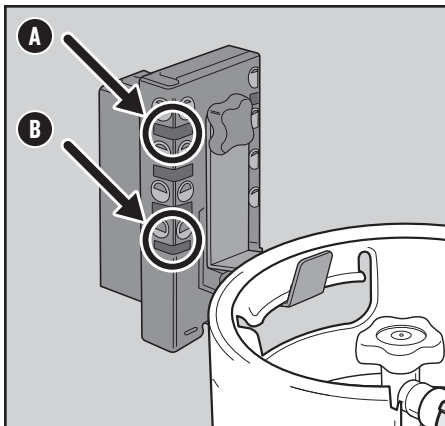

## Leak Checking

### What is a Leak Check?

Once the LPG cylinder is properly installed, it is necessary to perform a leak check. A leak check is a reliable way to verify that gas is not escaping after you connect the cylinder. The fuel system in your barbecue features factory-made connections that have been thoroughly checked for gas leaks and the burners have been flame-tested.

WEBER recommends performing a thorough leak check after assembly, as well as annually. The following fittings should be tested:

- Where the regulator connects to the cylinder.
- Where the gas hose connects to the bulkhead.
- Where the bulkhead connects to the corrugated gas line.

### Checking for Gas Leaks

- 1) Wet fittings (A) with a soap and water solution, using a spray bottle, brush, or rag. You can make your own soap and water solution by mixing 20% liquid soap with 80% water; or, you can purchase leak check solution in the plumbing section of any hardware store.
- 2) Slowly open gas supply by turning tank valve anti-clockwise while checking for bubbles.
- 3) If bubbles appear there is a leak:
  - a) If the leak is at the cylinder (B), turn off the gas. DO NOT OPERATE THE BARBECUE. Disconnect the tank and return the tank to your local retailer.
  - b) If the leak is at the regulator (C), turn off the gas. NEVER ATTEMPT TO TIGHTEN THE REGULATOR WITH CYLINDER VALVE OPEN. DO NOT OPERATE THE BARBECUE.
  - c) If the leak is at any fittings indicated in illustration (D), re-tighten fitting with a wrench and recheck for leaks with soap and water solution. If leak persists, turn off the gas. DO NOT OPERATE THE BARBECUE.
  - d) If the leak is at any fittings indicated in illustration (E), turn off the gas. DO NOT OPERATE THE BARBECUE.

If a leak is present, contact the Customer Service Representative in your area using the contact information on our website.

- 4) If bubbles do not appear, leak checking is complete:
  - a) Turn gas supply off at the cylinder and rinse connections with water.

*NOTE: Since some leak test solutions, including soap and water, may be slightly corrosive, all connections should be rinsed with water after checking for leaks.*

### Additional Leak Check Precautions

The following fittings should be tested for gas leaks each time a cylinder is refilled and reinstalled:

- Where the regulator connects to the LPG cylinder (B) and at the regulator (C).

Follow the instructions for "Checking for Gas Leaks".

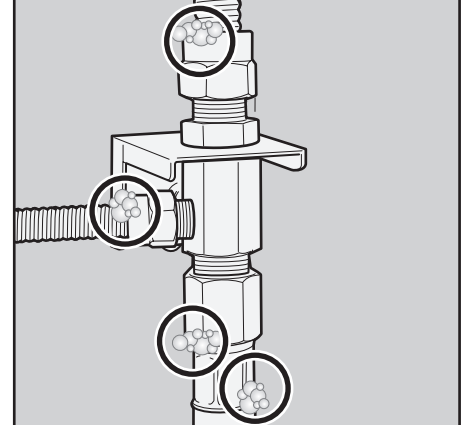
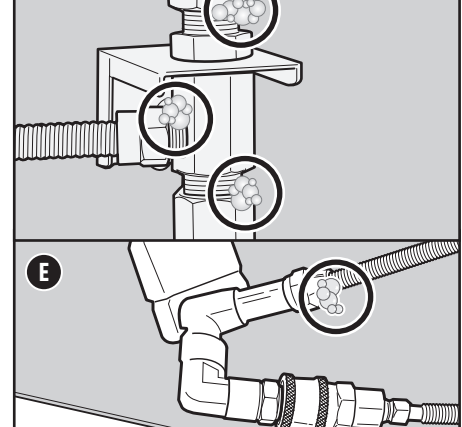
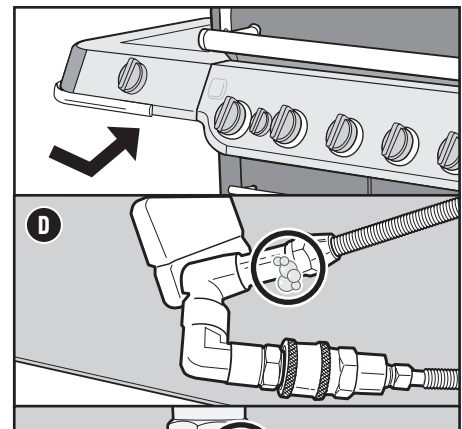
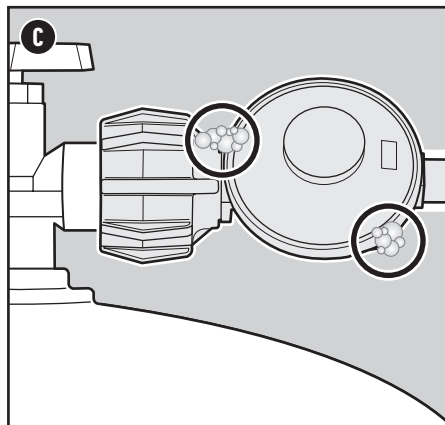
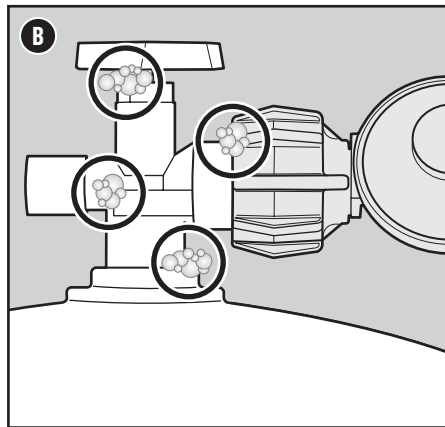
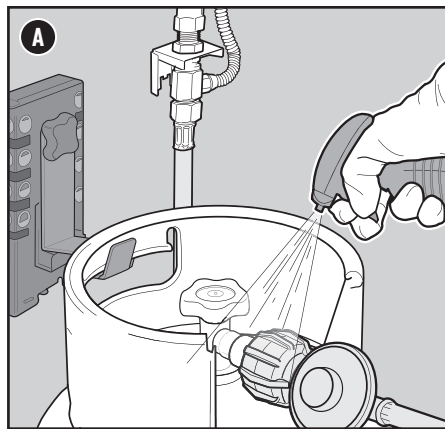

⚠ **DANGER:** Do not use a flame to check for gas leaks. Be sure there are no sparks or open flames in the area while you check for leaks.

⚠ **DANGER:** Leaking gas may cause a fire or explosion.

⚠ **DANGER:** Do not operate the barbecue if there is a gas leak present.

⚠ **DANGER:** If you see, smell, or hear the hiss of gas escaping from the LPG cylinder:

1. Move away from LPG cylinder.
2. Do not attempt to correct the problem yourself.
3. Call the emergency fire services.





⚠ **DANGER:** Always close the cylinder valve before disconnecting the regulator. Do not attempt to disconnect the gas regulator and hose assembly or any gas fitting while this barbecue is in operation.

⚠ **DANGER:** Do not store a spare LPG cylinder under or near this barbecue. Never fill the cylinder beyond 80% full. Failure to follow these statements exactly may result in a fire causing death or serious injury.

## Igniting the Main Burners

### Using the One-Handed Ignition to Ignite the Main Burners

Each control knob operates an individual burner, and each burner ignites independently. Ignite the main burners starting from left to right. All burners should be lit for preheating, however, all burners do not have to be lit while barbecuing.

- 1) Open the barbecue lid (A).
- 2) Check that all burner control knobs (including side burner control knob) are in the off  position. Check by pushing in and turning the knobs clockwise.  
*Note: It is important that all burner control knobs are in the off  position before turning on the LPG cylinder.*
- 3) Turn the LPG cylinder on by slowly turning the cylinder valve anti-clockwise; wait 60 seconds.  
*Note: It is important that the LPG cylinder is turned on slowly. See troubleshooting on page 13 for regulator reset instructions.*
- 4) Begin with the burner furthest to the left. Push the burner control knob in and slowly turn it anti-clockwise toward the ignite  position until you hear ticking (B). Once ticking starts, hold the knob in that position for 1-2 seconds and then slowly continue turning anti-clockwise. The burner should ignite before the high  position (C).
- 5) Check that the burner is lit by looking through the cooking grills and through the cutout in the FLAVORIZER bar.
- 6) If the burner does not ignite within 4 seconds, turn burner control knob to the off  position and wait five minutes to allow the gas to clear before attempting to light the burner again.
- 7) If the burner ignites, repeat steps 4 through 5 to ignite the remaining main burners.

Should the burners fail to ignite using the electronic ignition, refer to the TROUBLESHOOTING section. There you will find instructions on igniting the barbecue with a match to help determine the exact problem.

### Preheat the Barbecue

Preheating the barbecue is critical to successful barbecuing. Preheating helps to prevent food from sticking to the grill and gets the grill hot enough to sear properly. It also burns off any residue from the previous meal.

- 1) Open the barbecue lid.
- 2) Ignite your barbecue according to the ignition instructions in this owner's manual.
- 3) Close lid.
- 4) Preheat the barbecue with all burners on the high  position for 15 minutes (C).

### To Extinguish Main Burners

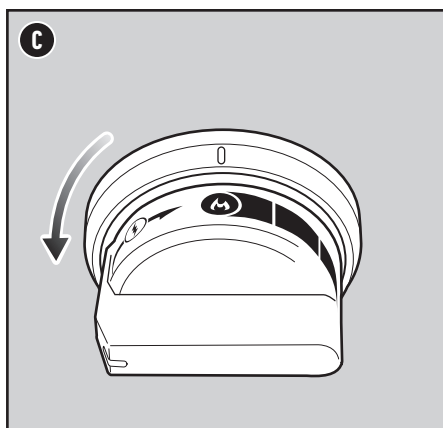
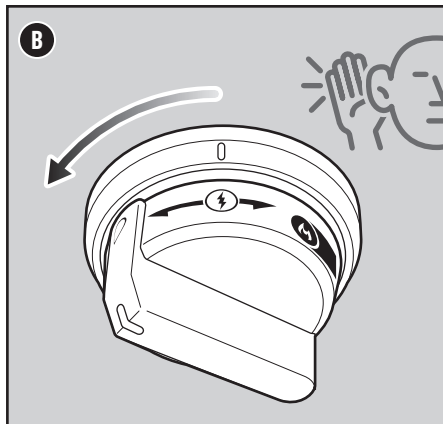
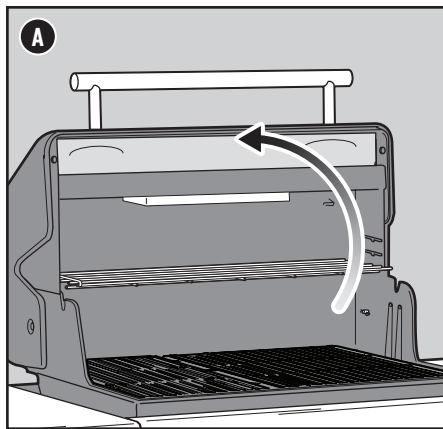

- 1) Push each burner control knob in and then turn clockwise all the way to the off  position.
- 2) Turn gas supply off at the LPG cylinder.  
*Note: It is important that all burner control knobs are turned off before turning off the gas cylinder or you may activate the flow limiting device built into the regulator, limiting the flow of gas from the ULPG cylinder.*  
*See troubleshooting on page 12 for reset instructions*

- ⚠ **WARNING:** Open lid during ignition.
- ⚠ **WARNING:** Do not lean over open barbecue while igniting or cooking.
- ⚠ **WARNING:** Each burner must be ignited individually.
- ⚠ **WARNING:** If ignition does not occur within four seconds of attempting to light the first burner, turn the burner control knob to the off position. Wait five minutes to allow accumulated gas to dissipate, and then repeat the lighting procedure.



## Using the Top-Down Infrared Burner

The top-down infrared burner directs blazing high heat onto the top of meat, searing the surface evenly and creating an edge-to-edge caramelised crust with juicy insides. As the heat comes from above, fats flow downward, minimising flare ups. The burner is thoughtfully sized to fit two porterhouse or four eye filet steaks perfectly, and the cooking grill below it adjusts to accommodate larger cuts of meat, casseroles, crème brûlée, and more.

- 1) Open the lid. Using heat-resistant barbecue gloves, adjust the level of the upper cooking surface to one of the three positions (A).
- 2) Push in the infrared burner control knob. Slowly turn it anti-clockwise toward the ignite  position until you hear ticking. Once ticking starts, hold the knob in that position for 1-2 seconds. Continue turning knob anti-clockwise, stopping halfway between the ignite and high heat  position (B). **Hold down** the knob in this position for 20 - 30 seconds as the burner ignites and establishes a continuous flow of gas across the surface of the infrared burner. Once the infrared burner is glowing orange, then it is ignited. Now turn the control knob to desired heat level and release the knob.
- 3) Keep the lid open while using the infrared burner in the high heat setting for searing (C). Use the infrared burner on the low heat setting for rotisserie/keep warm.

*Note: Always keep the lid OPEN while using the infrared burner on the high heat setting, and turn food frequently for even searing. Infrared burner performance could be sub-optimal while using the infrared burner and main burners simultaneously.*

### To Extinguish Infrared Burner

- 1) Push the control knob in and then turn clockwise all the way to the off  position.

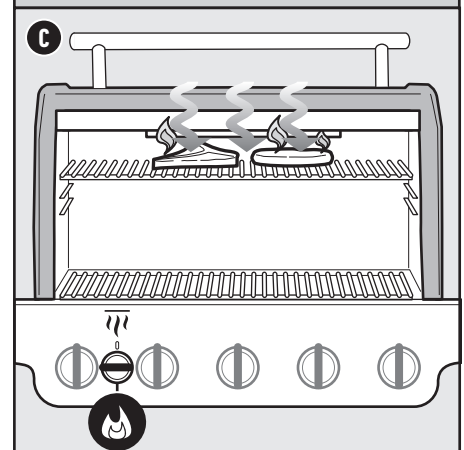
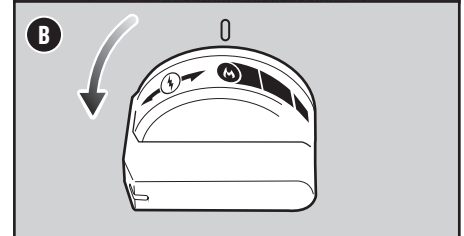
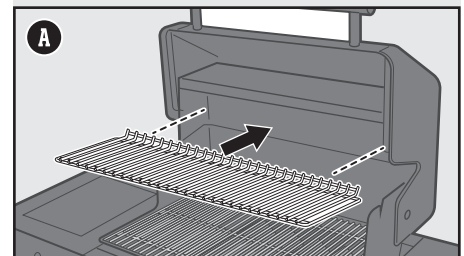

### Control Knob Settings





## Operating the Rotisserie

### Preparing the Barbecue

Prepare barbecue for rotisserie cooking by removing the warming rack and removing cooking grills (A).

**NOTE:** Set up the rotisserie with food before igniting the infrared burner.

- 1) To set up rotisserie motor, push the button on the retractable rotisserie panel (B). Pull rotisserie panel upwards. Push locking tab until it snaps into place. Unwind power cord and plug into power source.
- 2) To prepare the rotisserie for food, slide one rotisserie fork into the rotisserie rod (C). Push the rotisserie rod through the center of the food. Slide the second rotisserie fork into the rod and insert the tines of both rotisserie forks into the food. The food should be centered on the rod. Securely tighten both rotisserie fork screws.
- 3) Insert the pointed end of the rotisserie rod into the motor. Lower the rotisserie into the grooves on the cookbox (D).
- 4) Set infrared burner on the low heat setting.
- 5) Switch on the motor and close the lid.

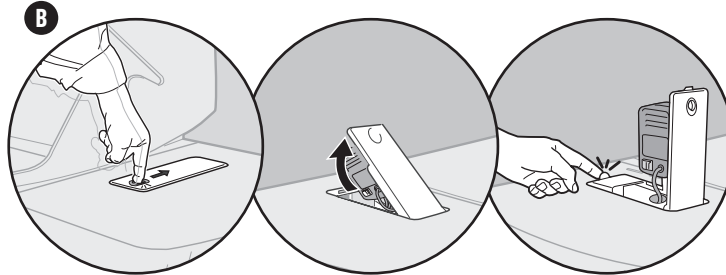
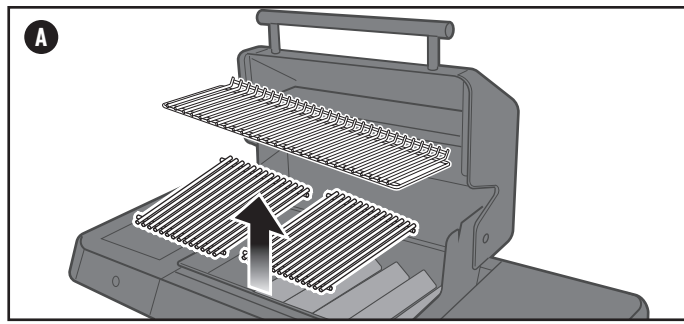

### Cooking Tips

- Before cooking, make sure that the food is centered and able to rotate. If food is too heavy or irregular in shape, it may not rotate well and should not be cooked using the rotisserie. In such cases, use the indirect method of cooking on the barbecue.
- Truss meat or poultry with string, if necessary, to make the shape as uniform as possible before putting it on the rotisserie.

### Use and Care

- Unplug the motor from outlet when not in use, or before cleaning.
- Use a soft cloth to clean the rotisserie motor. Do not use any chemicals or abrasive cleaners.
- Do not submerge motor, cord, or plug in water or other liquid.
- Hand wash rod and forks using mild dish detergent and then dry using soft cloth.
- When not in use, unplug the motor from outlet, remove from the barbecue and store in a dry place out of the reach of children.

### Rotisserie Motor Storage

- 1) Before retracting rotisserie back into the side table, unplug the power cord and carefully place plug/power cord into the storage area of the retractable rotisserie assembly (E).
- 2) Using your index finger, disengage retractable rotisserie panel. Push panel down until it snaps securely in place.

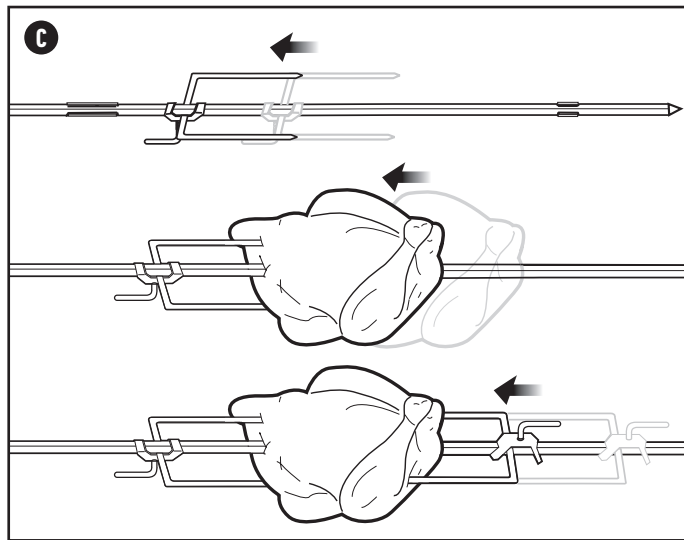

### Rotisserie Fork Storage

- 1) Remove forks from rotisserie spit.
- 2) Store rotisserie forks by placing them on the hooks located within the barbecue cabinet (F).

### Rotisserie Rod Storage

- 1) Store the rotisserie rod on the hooks on the back of the barbecue (G).

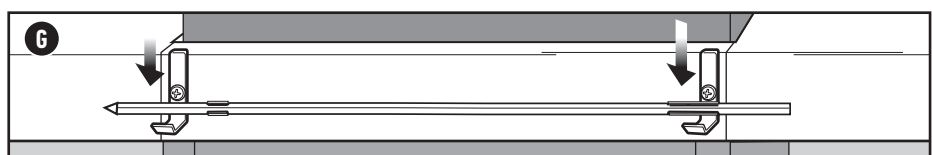
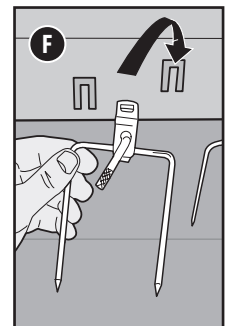
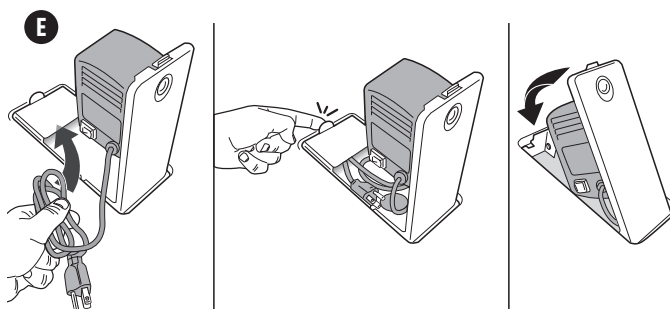
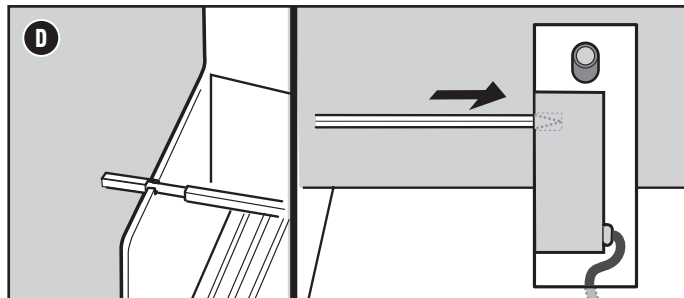

⚠ **CAUTION:** Do not route rotisserie motor power lead through the retractable rotisserie opening in the side table.

⚠ **CAUTION:** Inspect power lead before each use. If lead is damaged, do not use. Contact the Customer Service Representative in your area using the contact information on our web site. Log onto [www.weber.com](http://www.weber.com).







⚠ **CAUTION:** Failure to properly store the rotisserie power lead may result in damage to the power lead when opening and closing the retractable rotisserie panel.

⚠ **WARNING:** Use heat-resistant barbecue mitts or gloves when operating barbecue.

## Igniting the Side Burner

### Using the One-Handed Ignition to Ignite the Side Burner

If one or more of the main burners on your barbecue are already lit and you would like to ignite the side burner, skip to step 3. If none of the main burners are lit and you are only using the side burner, start with step 1.

- 1) Check that the side burner control knob is in the off  position. Check by pushing in and turning the knob clockwise (A). Also check that all main burners are in the off  position.  
*Note: It is important that all burner control knobs are in the off  position before turning on the LPG cylinder.*
- 2) Turn the LPG cylinder on by slowly turning the cylinder valve anti-clockwise; wait 60 seconds.  
*Note: It is important that the LPG cylinder is turned on slowly.*
- 3) Open the side burner lid (B).
- 4) Push the side burner control knob in and slowly turn it anticlockwise towards the ignite  position until you hear ticking (C). Once ticking starts, hold the knob in that position for 1-2 seconds and then slowly continue turning anticlockwise. The burner should ignite at the high  position (D).
- 5) Check that the side burner is lit. The side burner flame may be difficult to see on a bright sunny day.
- 6) Once side burner is ignited, continue turning the knob anticlockwise until you reach the desired position.
- 7) If the side burner does not ignite within 5 seconds, turn side burner control knob to the off  position and wait five minutes to allow the gas to clear before attempting to light the burner again.

Should the side burner fail to ignite using the electronic ignition, refer to the TROUBLESHOOTING section. There you will find instructions on igniting the side burner with a match to help determine the exact problem.

### To Extinguish Side Burner

- 1) Push side burner control knob in and then turn clockwise all the way to the off  position.
- 2) Turn gas supply off at the LPG cylinder.

- ⚠ **WARNING:** Open side burner lid during ignition.
- ⚠ **WARNING:** Do not lean over side burner while igniting or cooking.
- ⚠ **WARNING:** If ignition does not occur within four seconds of attempting to light the side burner, turn the burner control knob to the off position. Wait five minutes to allow accumulated gas to dissipate, and then repeat the lighting procedure.
- ⚠ **WARNING:** Over-sized cooking vessels must not be used with the side burner.

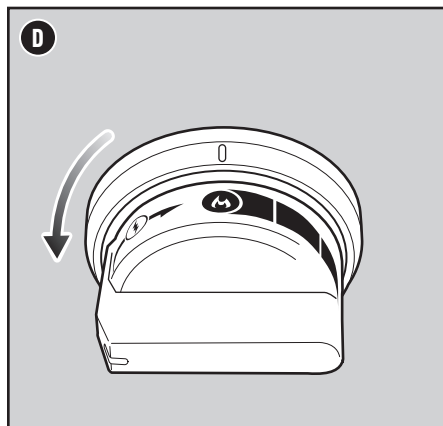
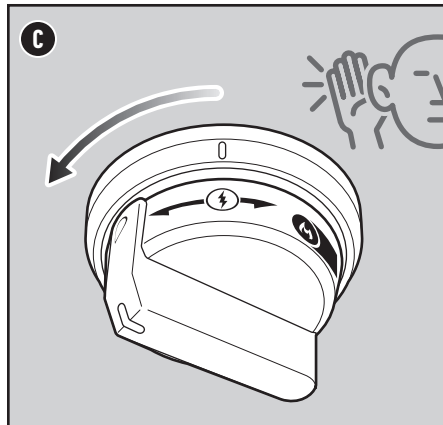
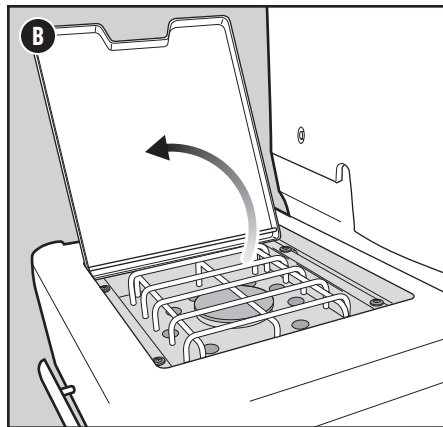
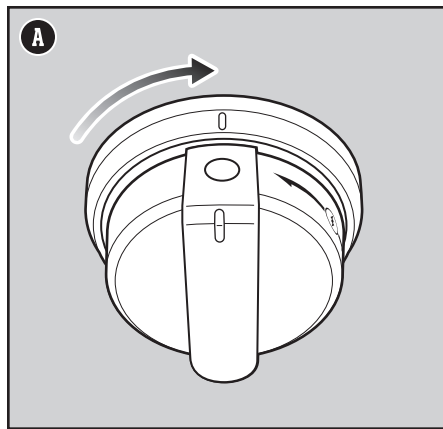

## Cleaning and Maintenance

### Cleaning the Inside of the Barbecue

Over time, the performance of your barbecue can diminish if it has not been maintained properly. Low temperatures, uneven heat, and food sticking to cooking grills are all signs that cleaning and maintenance are overdue. When your barbecue is off and cool, start by cleaning the inside from the top down. A thorough cleaning is recommended at least twice a year. Consistent use may require quarterly cleanings.

### Cleaning the Lid and the Upper Cooking Surfaces

From time to time you may notice 'paint-like' flakes on the inside of the lid. During use, grease and smoke vapours slowly change into carbon and deposit on the inside of your barbecue's lid. These deposits will eventually peel, and look very similar to paint. These deposits are non-toxic, but the flakes could fall onto your food if you do not clean the lid regularly.

- 1) Brush the carbonised grease from the inside of the lid and upper surfaces with a stainless steel bristle barbecue brush (A). To minimise further build-up, the inside of the lid can be wiped with a paper towel after barbecuing while the barbecue is still warm (not hot).

**IMPORTANT:** Do not brush the ceramic surface of the infrared broiler.

### Cleaning the Cooking Grills

Cleaned grills will prevent your next meal from sticking. If you are cleaning your cooking grills regularly, the debris on your grills will be minimal.

- 1) With grills installed, brush the debris off your cooking grill with a stainless steel bristle barbecue brush (B).
- 2) Take the grills out and set aside while you conduct further cleaning, then replace.

### Cleaning the FLAVORIZER BARS

FLAVORIZER BARS catch drippings that smoke and sizzle, adding flavour to your food. Any drippings that are not vaporised by the FLAVORIZER BARS are funnelled away from the burners. This helps prevent flare-ups inside of your barbecue, and protects the burners from getting clogged.

- 1) Scrape the FLAVORIZER BARS with a plastic scraper (C).
- 2) If necessary, brush the FLAVORIZER BARS with a stainless steel bristle barbecue brush.
- 3) Remove FLAVORIZER BARS and set aside while you conduct further cleaning, then replace.

### Cleaning the Burners

Two areas on the burners that are key to optimum performance are the ports (small raised openings running along the length of the burners) and the spider/insect screens on the ends of the burner. Keeping these areas clean is essential for safe operation.

#### Cleaning the Burner Ports

- 1) Use a clean stainless steel bristle barbecue brush to clean the outside of the burners by brushing across (not along) the top of the burner ports (D).
- 2) When cleaning the burners, avoid damaging the ignition electrode by carefully brushing around it.

#### Cleaning the Spider Screens

- 1) Locate the ends of the burners on the underside of the control panel where they meet the valves.
- 2) Clean the spider/insect screens on each of the burners using a soft bristle brush (E).

### Cleaning the Heat Deflectors

Located under the burners, the heat deflectors distribute heat evenly throughout the cookbox while cooking. Keeping heat deflectors clean will enhance the cooking performance of your barbecue.

- 1) Scrape the heat deflectors with a plastic scraper.
- 2) If necessary, brush the heat deflectors with a stainless steel bristle barbecue brush.
- 3) Remove heat deflectors and set aside while you conduct further cleaning, then replace.

### Cleaning the Cookbox

Look inside the cookbox for any grease accumulation or leftover food particles. Excessive accumulation can cause a fire.

- 1) Use a plastic scraper to scrape debris off the sides and bottom of the barbecue into the opening in bottom of the cookbox. This opening leads debris into the slide-out grease tray.

### Cleaning the Grease Management System

The grease management system consists of an angled slide-out grease tray and a catch pan. These components were designed to be easily removed, cleaned, and replaced; an essential step every time you prepare to barbecue.

### Cleaning the Outside of the Barbecue

The outside of your barbecue may include stainless steel, porcelain-enamelled, and plastic surfaces. WEBER recommends the following methods based on the surface type.

#### Cleaning Stainless Steel Surfaces

Clean stainless steel using a non-toxic, non-abrasive stainless steel cleaner or polish designed for use on outdoor products and barbecues. Use a microfibre cloth to clean in the direction of the grain of the stainless steel. Do not use paper towels.

*Note: Do not risk scratching your stainless steel with abrasive pastes. Pastes do not clean or polish. They will change the colour of the metal by removing the top chromium oxide film coating.*

#### Cleaning Painted, Porcelain-Enamelled Surfaces and Plastic Components

Clean painted, porcelain-enamelled and plastic components with warm soapy water, and paper towels or cloth. After wiping down the surfaces, rinse and dry thoroughly.

#### Cleaning the Outside of Barbecues that are in Unique Environments

If your barbecue is subject to a particularly harsh environment, you will want to clean the outside more often. Acid rain, pool chemicals, and salt water can cause surface rusting to appear. Wipe down the outside of your barbecue with warm soapy water. Follow up with a rinse and thorough drying. Additionally, you may want to apply a stainless steel cleaner weekly to prevent surface rust.

#### Cleaning the Inside of the Cabinet

Use a soft, damp cloth to wipe the interior of the cabinet. Be careful not to pull any of the wire connections when cleaning around the electronic components.

#### Replacing Batteries for the Battery Pack

The battery pack operates the lights on the control knobs and the gas gauge. Use alkaline batteries only. Do not mix old and new batteries or different types of batteries (standard, alkaline, or rechargeable). If you do not plan to use the barbecue for a month or more, remove the batteries.

- 1) Locate the battery housing on the inside of the cabinet on the bottom right side.
- 2) Press the tabs on the battery door to open (F).
- 3) Replace six D batteries.

**CAUTION: NEVER SPRAY THE BARBECUE WITH A STEADY WATER STREAM SUCH AS FROM A GARDEN HOSE OR POWER WASHER. ELECTRONIC COMPONENTS COULD BECOME DAMAGED.**

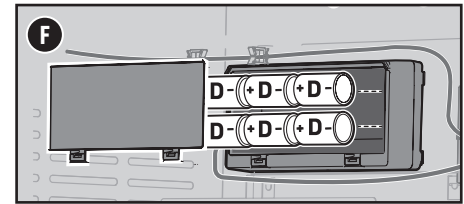
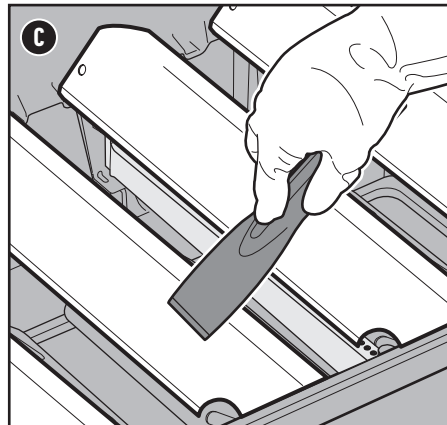
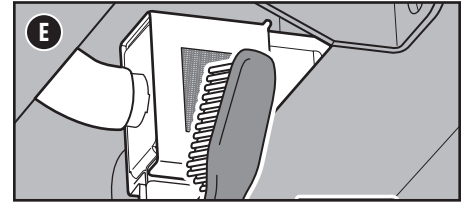
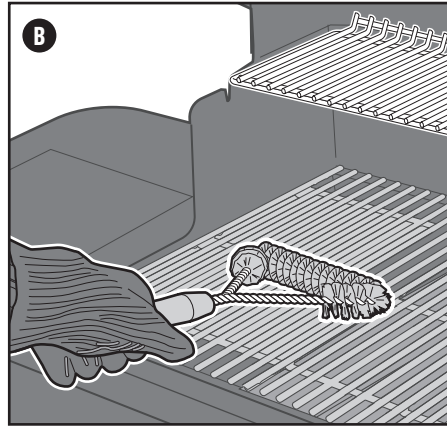
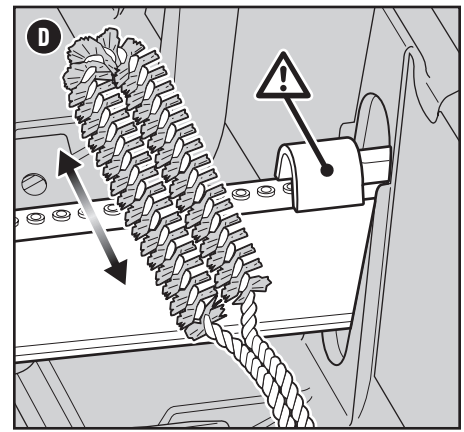
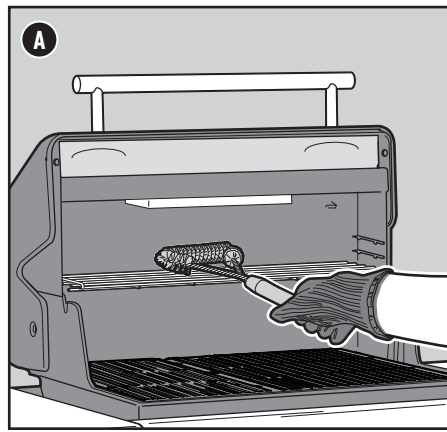

⚠ **WARNING:** Turn your barbecue off and wait for it to cool before thoroughly cleaning it.

⚠ **WARNING:** Over time, the development of rough surfaces can form on the FLAVORIZER BARS. Wearing gloves is recommended when handling. Do not clean FLAVORIZER BARS or cooking grills in a sink, dishwasher, or self-cleaning oven.

⚠ **WARNING:** When cleaning the burners, never use a brush that has already been used to clean the cooking grills. Never put sharp objects into the burner port holes.

⚠ **CAUTION:** Do not place any barbecue components onto the side tables as they may scratch the paint or stainless steel surfaces.

⚠ **CAUTION:** Do not use any of the following to clean your barbecue: abrasive stainless steel polishes or paints, cleaners that contain acid, mineral spirits or xylene, oven cleaner, abrasive cleansers (kitchen cleansers), or abrasive cleaning pads.

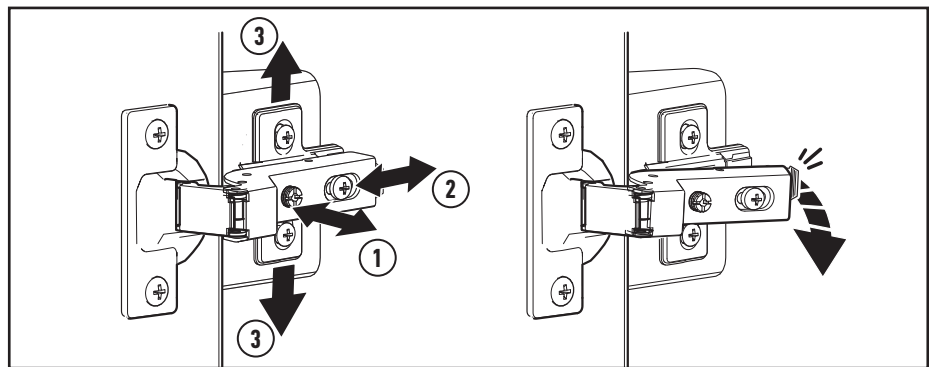

#### Adjust Door Alignment

Each soft-close hinge is capable of adjustment in case it is necessary to align the cabinet doors.

- 1) The front screw on the hinge body adjusts the door horizontally, left and right (1).
- 2) The rear screw on the hinge body adjusts the depth of the door, back and forth (2).
- 3) To adjust the door vertically, loosen the two screws on the hinge bracket to slide the door up and down, then retighten the screws (3).

#### Door Removal

To remove the door, it is not necessary to remove any screws from the hinges. Pull the small release lever located behind the body of the hinge. The hinge bracket remains installed to the frame as the door is removed.

#### Reattach Door

To reattach the door, hook the base of the hinge to the bracket on the cabinet frame. Then, push the body of the hinge until it snaps into the bracket.

## MAIN BURNER(S), SIDE BURNER or INFRARED BURNER WILL NOT IGNITE

### SYMPTOM

- Main burners, side burner or infrared burner does not ignite when following the electronic ignition instructions in the “Operation” section of this owner’s manual.

### CAUSE

There is a problem with gas flow.

There is a problem with the electronic ignition system.

Did you hold the infrared broiler control knob in for 20 seconds after burner ignited, and wait to see the entire ceramic surface of the infrared broiler become alight?

### SOLUTION

If any burner does not ignite, the first step is to determine if there is gas flowing to the burner(s). To check this, follow the instructions below for “Lighting Your Barbecue with the Matchstick Holder, Long-Reach Lighter or Long Match.”  
If **match lighting IS NOT successful**, follow the instructions for disconnecting and reconnecting the LPG cylinder.





If any burner does not ignite, the first step is to determine if there is gas flowing to the burner(s). To check this, follow the instructions below for “Lighting Your Barbecue with a Long-Reach Lighter.”

If **match lighting IS successful**, check the condition of the battery and check the wire connections of the Electronic Ignition System.





Try to relight burner by holding burner control knob in; continue holding in until 20 seconds after burner has ignited, and wait to see the entire ceramic surface become alight.

## Lighting Your Barbecue with the Matchstick Holder, Long-Reach Lighter or Long Match

### Using the Matchstick Holder, Long-Reach Lighter or Long Match to Determine if there is Gas Flow to the Main Burners

- 1) Open the barbecue lid.
- 2) Check that all burner control knobs (including side burner control knob) are in the off  position. Check by pushing in and turning knobs clockwise.  
*Note: It is important that all burner control knobs are in the off  position before turning on the LPG cylinder.*
- 3) Turn the LPG cylinder on by slowly turning the cylinder valve anti-clockwise; wait 60 seconds.  
*Note: It is important that the LPG cylinder is turned on slowly.*
- 4) Begin with the burner furthest to the left. Insert a lit long-reach lighter down through the cooking grills, past the FLAVORIZER BARS and next to the burner **(A)**.
- 5) Push the burner control knob in and slowly turn it anti-clockwise toward the start/high  position.
- 6) Check that the burner is lit by looking through the cooking grills and through the cutout in the FLAVORIZER bar.
- 7) If the burner does not ignite within 5 seconds, turn burner control knob to the off  position and wait five minutes to allow the gas to clear before attempting to light the burner again. If repeated attempts fail, follow the gas flow troubleshooting instructions on the next page.
- 8) If the burner ignites, the problem lies in the ignition system. Check the condition of the batteries and check the wire connections of the Electronic Ignition System.

### Using the Matchstick Holder, Long-Reach Lighter or Long Match to Determine if there is Gas Flow to the Side Burner or Infrared Burner

- 1) Open the side burner lid and the barbecue lid.
- 2) Check that all burner control knobs (including side burner control knob) are in the off  position. Check by pushing in and turning knobs clockwise.  
*Note: It is important that all burner control knobs are in the off  position before turning on the LPG cylinder.*
- 3) Turn the LPG cylinder on by slowly turning the cylinder valve anti-clockwise; wait 60 seconds.  
*Note: It is important that the LPG cylinder is turned on slowly.*
- 4) Hold a lit long-reach lighter by the side burner **(B)** or by the infrared broiler **(C)**.
- 5) Push the side burner control knob or infrared burner control knob in and slowly turn it counterclockwise toward the high  position. For the infrared burner, continue to hold the control knob down until twenty seconds after the burner has ignited.
- 6) Check that the side burner or infrared burner is lit. The flame may be difficult to see on a bright sunny day.
- 7) If the burner does not ignite within 4 seconds, turn side burner control knob to the off  position and wait five minutes to allow the gas to clear before attempting to light the burner again.
- 8) If the burner ignites, the problem lies in the ignition system. Check the condition of the battery and check the wire connections of the Electronic Ignition System.

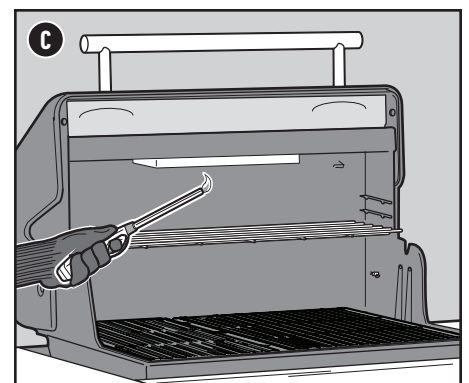
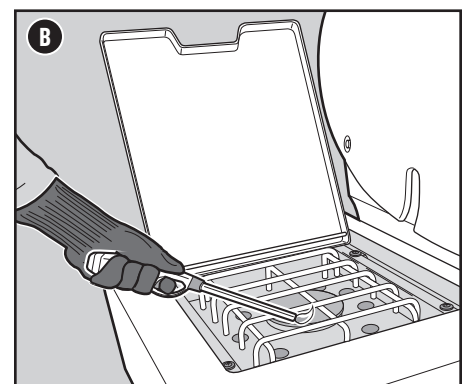
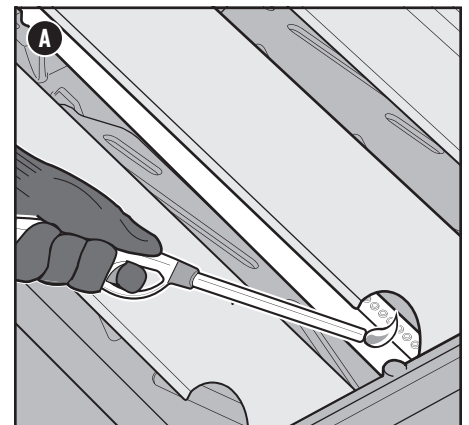
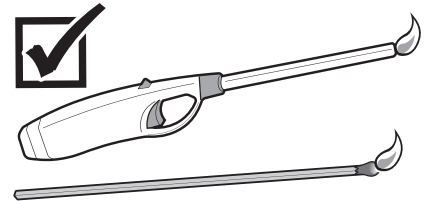

## CALL CUSTOMER SERVICE

If you are still experiencing any problems, contact Weber ANZ customer service or log onto [weber.com](http://weber.com).

Australia: 1 300 301 290  
New Zealand: 0800 493 237

## GAS FLOW

### SYMPTOM

- Barbecue does not reach desired temperature or heats unevenly.
- One or more of the burners fail to ignite.
- Flame is low when burner is on high position.
- Flames do not run the whole length of the burner.
- Burner flame pattern is erratic.

CAUSE	SOLUTION
The cylinder is low or empty.	Refill cylinder.
Fuel hose is bent or kinked.	Straighten fuel hose.
Burner ports are dirty.	Clean burner ports. Refer to "Cleaning the Burner Ports."
Regulator Flow Limiting Device has been activated.	Reset the regulator following the instructions below.

### SYMPTOM

- Gas is smelled in conjunction with burner flames that appear yellow and lazy.

CAUSE	SOLUTION
Spider screens on the burners are obstructed.	Clean spider screens. Refer to "Cleaning the Spider Screens" in the Product Care section. Also refer to the illustrations and information in this section about proper flame pattern and spider screens.

### SYMPTOM

- The smell of gas and/or a light hissing sound.

CAUSE	SOLUTION
The internal rubber seal in the cylinder valve could be damaged.	Inspect the rubber seal for damage. If damaged, return cylinder to local retailer.

### Regulator Flow Limiting Reset Guide.

- 1) Turn off barbecue control knob(s). There is no need to turn off the gas cylinder.
- 2) Wait 30 seconds.
- 3) Open the top cover.
- 4) Light barbecue per lighting instructions on page 7.

**NOTE: Always turn your barbecue control knob(s) off before turning off your gas cylinder.**

### Proper Burner Flame Pattern

The burners in your barbecue were factory set for the correct air and gas mixture. When the burners are performing correctly, you will see a specific flame pattern. The tips may occasionally flicker yellow (A), with a descending light blue (B) to dark blue flame (C).

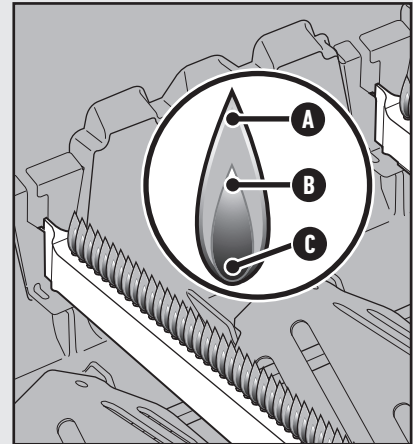

### Spider Screens

The combustion air openings of the burners (D) are fitted with stainless steel screens to prevent spiders and other insects from spinning webs and building nests inside the venturi section of the burners. These nests can obstruct the normal gas flow, and can cause gas to flow back out of the combustion air opening. Symptoms of this kind of obstruction include the odour of gas in conjunction with burner flames that appear yellow and lazy. This obstruction could result in a fire in and around the gas valve, causing serious damage to your barbecue. Dust and debris can accumulate on the outside of the spider/insect screen and obstruct the oxygen flow to the burners. Keep the spider screens clean. Refer to "Cleaning the Spider Screens" in the Product Care section.

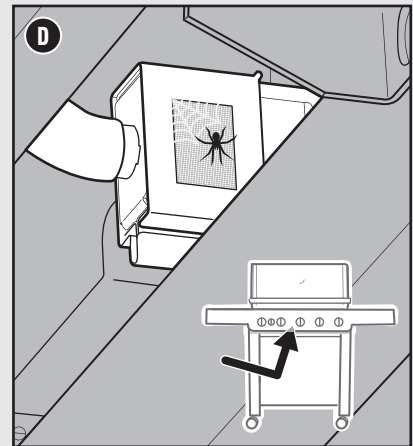

## REPLACEMENT PARTS

To obtain replacement parts, contact Weber ANZ customer service or log onto [weber.com](http://weber.com).  
 Australia: 1 300 301 290  
 New Zealand: 0800 493 237

**⚠ WARNING: Do not attempt to make any repair to gas carrying, gas burning, ignition components or structural components without contacting Weber-Stephen Products LLC, Customer Service Department.**

**⚠ CAUTION: The burner tube openings must be positioned properly over the valve orifices.**

## Checking the Components of the Electronic Ignition System

When pressing the ignition button you should hear a ticking sound. If you cannot hear the ticking sound, check the battery, then check the wires. Remove the heat shield to check these components.

### Checking the Battery

There are three potential issues with the battery that supplies the power to your ignition module that need to be checked:

- 1) Some batteries have a plastic protective wrap around them. (Do not confuse this plastic with the battery label.) Check that this plastic wrap is removed.
- 2) Confirm that the battery is installed correctly (C).
- 3) If the battery is old, replace it with a new battery.

### Checking the Wires

There are two potential trouble spots that need to be checked:

- 1) Check that the ignition wires are connected securely to the terminals on the ignition button under the control panel.
- 2) Make sure the ignition wires are properly attached to the ignition module. The wire terminals are colour coded to correspond with the terminals on the ignition module. The number of wires will vary per model.

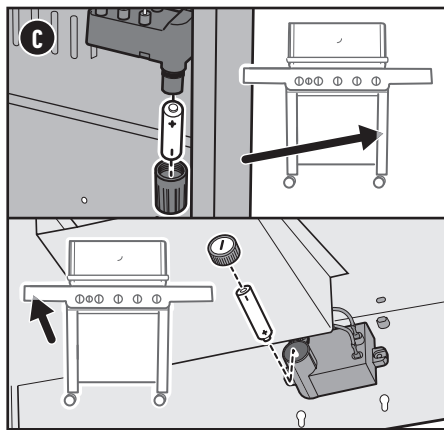

## Igniter Module Wire Chart

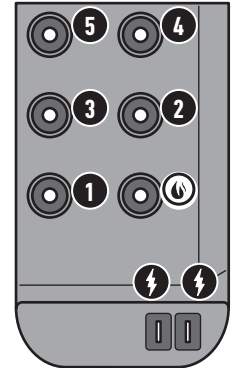
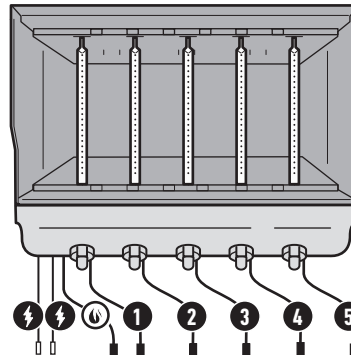

# Barbecuing at Night

*This feature is only available on selected models.*

## Using the NIGHTVISION Lighting

To activate the NIGHTVISION light press the awake button. The barbecue light has a tilt sensor that will turn on the light if the barbecue lid is opened and turn off the light when the barbecue lid is closed. If the lid is left open or closed for more than 30 minutes, the barbecue light will be deactivated automatically. To turn the light back on, press the AWAKE button.

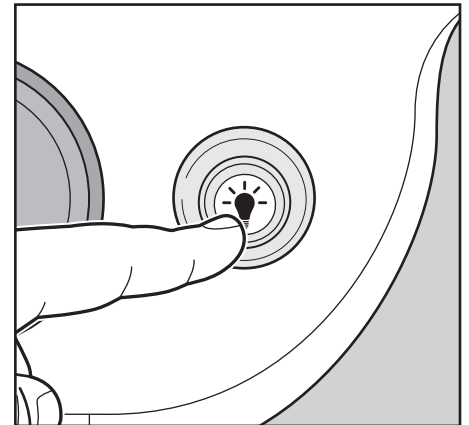
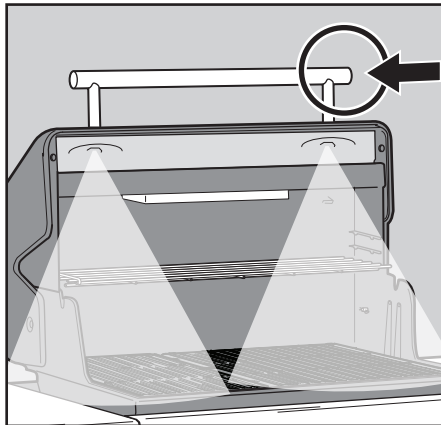

## Using the Lighted Control Knobs

The burner control knobs light up with the push of a button. To turn on or off, simply push the power button located on the right side of the control panel.

## Replacing Batteries for the NIGHTVISION Lighting

Use alkaline batteries only. Do not mix old and new batteries or different types of batteries (standard, alkaline, or rechargeable). If you do not plan to use the barbecue for a month or more, remove the batteries.

- 1) Close the lid. Locate the battery housing on the side of the lid handle and unscrew the cap (A). Do not change batteries with the lid open.
- 2) Remove the battery sleeve.
- 3) Replace three size C batteries (B).
- 4) Line up graphic indicators (C) on the sleeve and handle as you reinstall the sleeve. Tighten cap.

*NOTE: Periodically wipe the lenses with a damp cloth to keep the lights illuminating brightly.*

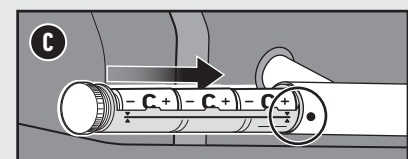
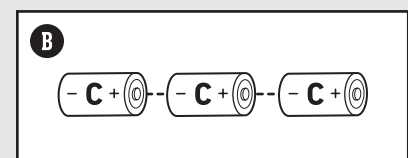
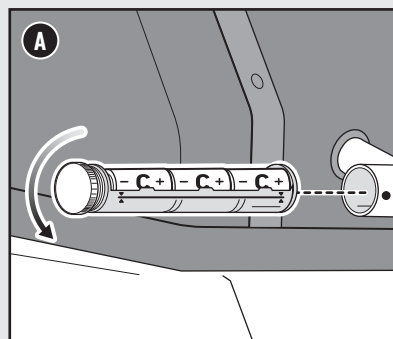

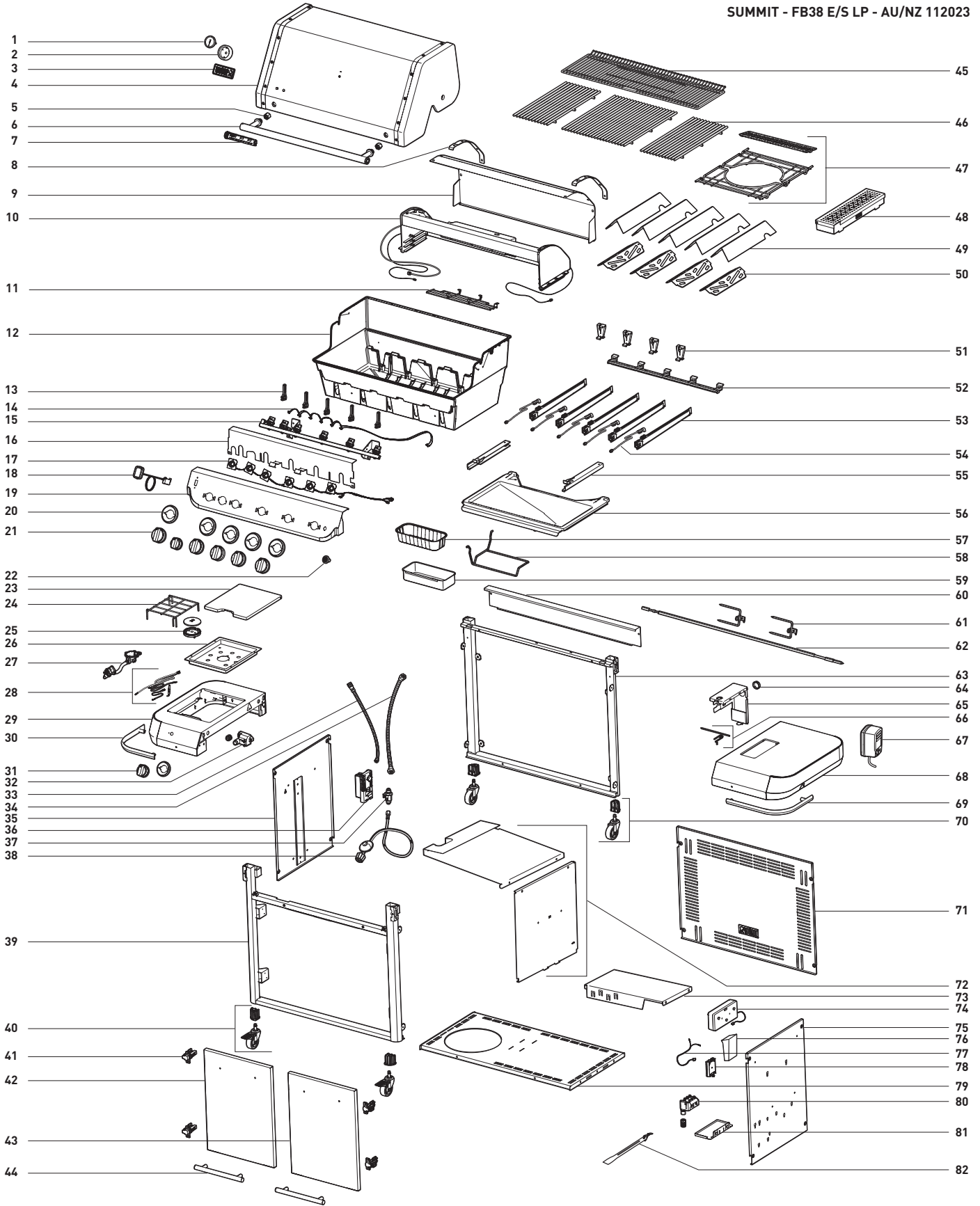



**PROBLEMS? QUESTIONS?** Do Not Return Product to the Store. We Can Help.

If you have questions about the assembly, use, or maintenance of your barbecue or need replacement parts, please contact Weber Customer Service. The serial number and model number can be found on the cover of your owner's manual and will be necessary for all service calls.

[weber.com](http://weber.com)

**Weber-Stephen Products Co (Australia) Pty Ltd.**

Level 1, 142-144 Fullarton Road  
ROSE PARK SA 5067 AUSTRALIA  
+61 8 8221 6111 | [www.weber.com](http://www.weber.com)

**Weber-Stephen Products New Zealand**

25B O'Rorke Road  
Penrose, Auckland 1061 NEW ZEALAND  
+64 9 279 7133 | [www.weber.com](http://www.weber.com)